

Order example

MCJA – 12 – 40 – 25 M – □

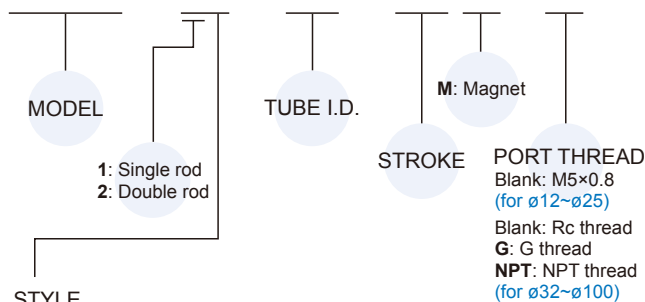

Code	Symbol	Description
1 1		Double acting / Male thread
1 2		Double acting / Female thread
1 3		Single acting / Normally extended male thread
1 4		Single acting / Normally extended female thread
1 5		Single acting / Normally returned male thread
1 6		Single acting / Normally returned female thread
2 1		Double rod / Male thread
2 2		Double rod / Female thread
2 7		Double rod / Adjustable male thread
2 8		Double rod / Adjustable female thread

* Order example for special specification, refer to page 0-7.

Features

- Ultra Compact, light weight and space saving cylinder.
- Wide range of bore sizes and strokes (12mm~100mm).
- Single and double acting available.
- Ideal for use in machinery where space is limited and incorporating sensor groove which enables flush fitting of sensors.

Specification

Model	MCJA									
Acting type	Double acting / Single acting			Double acting						
Tube I.D. (mm)	12	16	20	25	32	40	50	63	80	100
Port size	M5×0.8			Rc1/8	Rc1/4	Rc3/8				
Medium	Air									
Operating pressure range (MPa)	Double acting		0.05~1	0.03~1	0.02~1					
	Single acting		0.2~1	0.15~1	0.1~1	—				
Proof pressure	1.5 MPa									
Ambient temperature	-5°C~+60°C (No freezing)									
Available speed range	50~500 mm/sec									
Sensor switch (*)	RCB, RCE, RCE1, RDEP									

* RCB, RCE, RCE1, RDEP specification, please refer to page 8-8, 10, 14.

Double acting – Table for standard stroke

	Tube I.D.	Stroke (mm)	Max. stroke
Single rod	ø12,16	5,10,15,20,25,30	300
	ø20,25,32 ø40,50,63	5,10,15,20,25,30,35,40,45,50	300
	ø80,100	5,10,15,20,25,30,35,40,45,50	125
Double rod	ø12,16	5,10,15,20,25,30	300
	ø20,25,32 ø40,50,63,80	5,10,15,20,25,30,35,40,45,50	300
	ø100	5,10,15,20,25,30,35,40,45,50	125

- Stroke out of specification is also available
- Please consult us if stroke out of specification.

Single acting – Table for standard stroke

Tube I.D.	Stroke (mm)
ø12,16,20,25,32,40	5,10,15,20,25,30
ø50	5,10,15,20

- Stroke out of specification is also available
- Please consult us if stroke out of specification.

Double acting

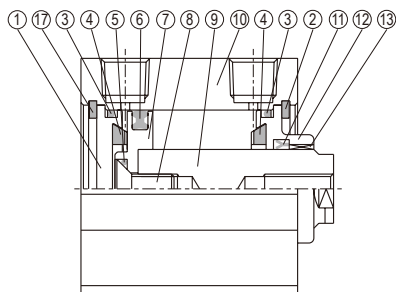

Single acting

Normally returned

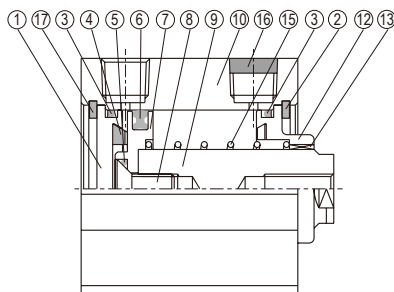

Single acting

Normally extended

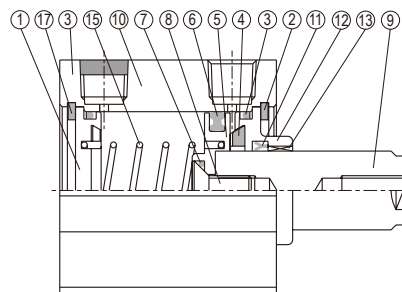

Seal kit

Acting type	Rod packing		Piston packing		Cover ring	Piston gasket
	Double action normally extended	Normally returned	Double acting	Single acting	Double acting single acting	Double acting single acting
Q'y	1	0	1	1	2	1
12	KSYR-6	—	OPA-12	OPA-12	S-12	d4×w1
16	KSYR-6	—	OPA-16	OPA-16	S-14	d4×w1
20	KSYR-8	—	OPA-20	OPA-20	S-18	d6×w1
25	KSYR-10	—	OPA-25	OPA-25	S-22	d8×w1
32	KSYR-12	—	OPA-32	OPA-32	d28×w2	S-9
40	KSYR-16	—	OPA-40	OPA-40	S-36	S-9
50	KSYR-20	—	OPA-50	OPA-50	AS-31	S-16
63	KSYR-20	—	OPA-63	—	AS-35	S-16
80	ORA-25	—	OPA-80	—	AS-41	d20×w1
100	SDR-30	—	OPA-100	—	S-95	S-26

Double acting

(with magnet)

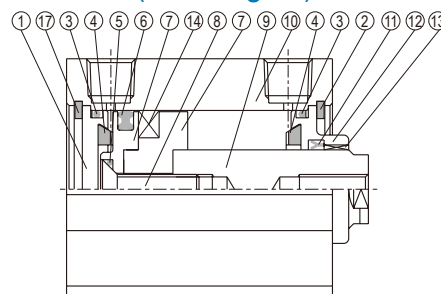

Material

No.	Tube I.D. Part name	12	16	20	25	32	40	50	63	80	100	Q'y	Component parts (inclusion)	Repair kits (inclusion)	
1	Head cover	Aluminum alloy										1	●		
2	Snap ring (Front end)	SUS	spring steel	SUS	Spring steel								1	●	
3	Cover ring	NBR										2	●	●	
4	Cushion packing	—	NBR									2	●	●	
5	Piston gasket	NBR										1	●	●	
6	Piston packing	NBR										1	●	●	
7	Piston	Aluminum alloy										1	●		
8	Screw	With magnet	Stainless steel		SCM							1	●		
		Without magnet	SCM	SUS	SCM							1	●		
9	Piston rod	With magnet	Stainless steel		Carbon steel							1			
		Without magnet	SUS	Carbon steel							1				
10	Body	Aluminum alloy										1			
11	Rod packing	NBR										1(*)	●	●	
12	Rod cover	Aluminum alloy										1	●		
13	Bush	—	Bearing alloy								1	●			
14	Magnet ring	Magnet material										1	●		
15	Spring	SWP		—							1	●			
16	Silencer	Brass										—	1	●	
17	Snap ring (Rear end)	Stainless steel				Spring steel							1	●	

* Single acting / Normally returned, Q'y=0.

Order example Component parts

Tube I.D.	Component parts
ø12	CP-MCJA-12(M)
ø16	CP-MCJA-16(M)
ø20	CP-MCJA-20(M)
ø25	CP-MCJA-25(M)
ø32	CP-MCJA-32(M)
ø40	CP-MCJA-40(M)
ø50	CP-MCJA-50(M)
ø63	CP-MCJA-63(M)
ø80	CP-MCJA-80(M)
ø100	CP-MCJA-100(M)

M: With magnet

Repair kits

Tube I.D.	Repair kits
ø12	PS-MCJA-12
ø16	PS-MCJA-16
ø20	PS-MCJA-20
ø25	PS-MCJA-25
ø32	PS-MCJA-32
ø40	PS-MCJA-40
ø50	PS-MCJA-50
ø63	PS-MCJA-63
ø80	PS-MCJA-80
ø100	PS-MCJA-100

COMPACT CYLINDER

mindman

$\phi 12, \phi 16$

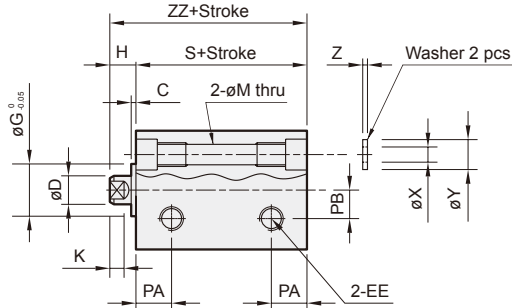
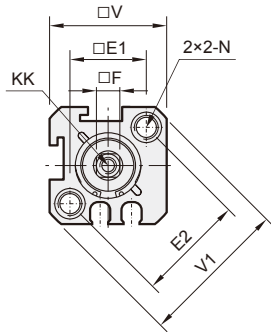

Long stroke

Without counter bore

With magnet type:
The stroke length must be over 100mm.
Without magnet type:
The stroke length must be over 110mm.

$\phi 12, \phi 16$



$\phi 20\sim\phi 100$



$\phi 20, \phi 25$

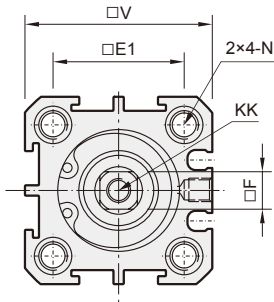

$\phi 32\sim\phi 100$

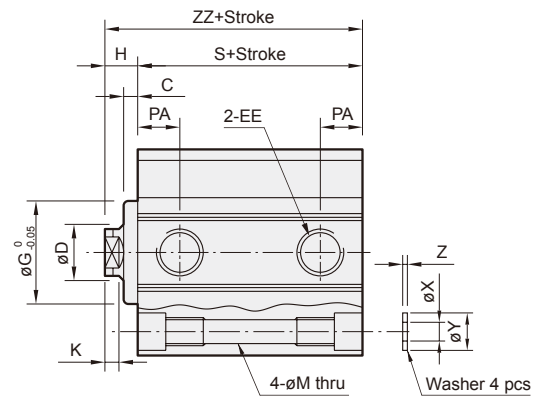
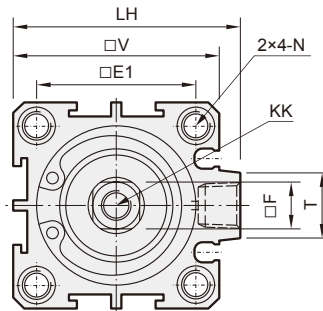

Code Tube I.D.	C	D	EE	E1	E2	F	G	H	K	KK	LH	M	N	PA	PB
12	1	6	M5×0.8	16.3	23	5	11	5	3	M3×0.5×6depth	—	4.3	ø6.5×4.5depth, M5×0.8×7.5depth	6.5	6
16	1.5	6	M5×0.8	19.8	28	5	11	5.5	3	M3×0.5×6depth	—	4.3	ø6.5×4.5depth, M5×0.8×7.5depth	7	6.5
20	1.5	8	M5×0.8	24	—	6	15	5.5	3	M4×0.7×8depth	—	4.3	ø6.5×4.5depth, M5×0.8×7.5depth	7.5	—
25	2	10	M5×0.8	28	—	8	17	6	3	M5×0.8×10depth	—	5.1	ø9×7depth, M6×1.0×10depth	8	—
32	3	12	Rc1/8 (*1)	34	—	10	22	7	3	M6×1.0×12depth	48.5	5.1	ø9×7depth, M6×1.0×10depth	9	—
40	3	16	Rc1/8 (*1)	40	—	14	28	7	3	M8×1.25×12depth	56.5	6.9	ø10.5×8depth, M8×1.25×12depth	10	—
50	4	20	Rc1/4 (*2)	48	—	17	38	9	3	M10×1.5×15depth	70	6.9	ø11×8.5depth, M8×1.25×16.5depth	10	—
63	4	20	Rc1/4 (*2)	60	—	17	40	9	3	M10×1.5×15depth	83	6.9	ø11×8.5depth, M8×1.25×16.5depth	12	—
80	5	25	Rc3/8 (*3)	74	—	22	45	11	4	M14×1.5×20depth	102	10.5	ø14×10.5depth, M12×1.75×12depth	13	—
100	5	30	Rc3/8 (*3)	90	—	27	55	12	4	M18×1.5×20depth	122	12.3	ø18.5×13depth, M14×2×17depth	17	—

*1. Without magnet with stroke=5mm, EE=M5×0.8

*2. Without magnet with stroke=5mm, EE=Rc1/8

*3. Without magnet with stroke=5mm, EE=Rc1/4

Code Tube I.D.	T	V	V1	X	Y	Z	Without magnet		Magnet	
							S	ZZ	S	ZZ
12	—	25	32	3.2	6.3	1	17	22	27	32
16	—	29	38	3.2	6.3	1	18.5	24	28.5	34
20	—	34	—	3.2	6.3	1	19.5	25	29.5	35
25	—	40	—	4.2	7.8	1	21	27	31	37
32	14	44	—	4.2	7.8	1	24.5	31.5	34.5	41.5
40	14	52	—	6.2	10.3	1.6	26	33	36	43
50	19	62	—	6.2	10.8	1.6	28	37	38	47
63	20	75	—	6.2	10.8	1.6	32	41	42	51
80	27	94	—	8.2	13.8	1.6	41	52	51	62
100	26	114	—	10.2	17.3	2	51	63	61	73

COMPACT CYLINDER

mindman

$\phi 12, \phi 16$

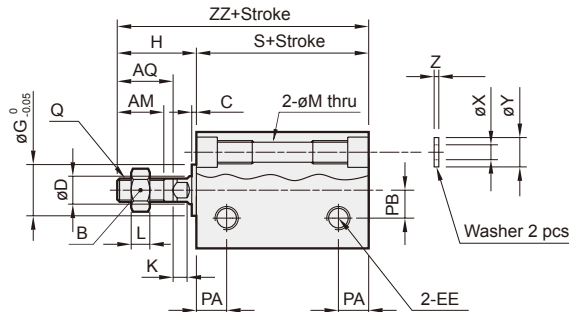
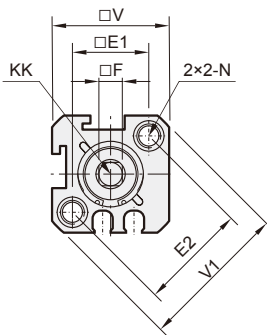

Long stroke
Without counter bore
 With magnet type:
 The stroke length must be over 100mm.
 Without magnet type:
 The stroke length must be over 110mm.

$\phi 12, \phi 16$

$\phi 20\sim\phi 100$

$\phi 20, \phi 25$

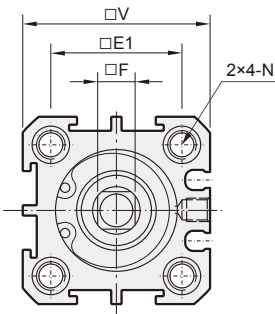

$\phi 32\sim\phi 100$

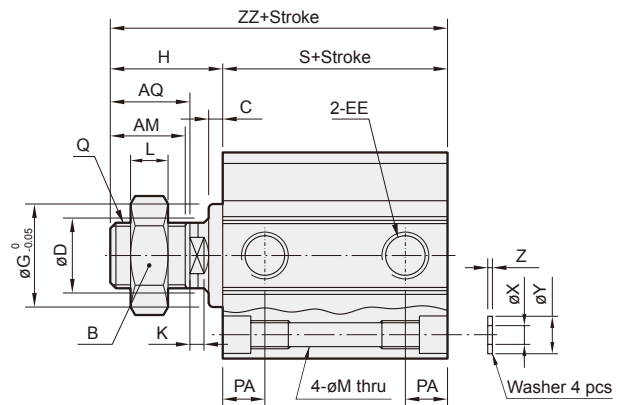
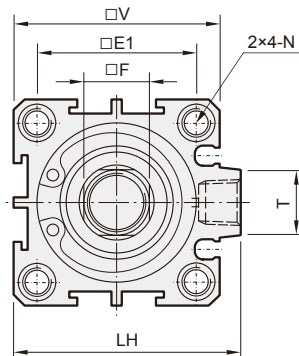

Code Tube I.D.	AM	AQ	B	C	D	EE	E1	E2	F	G	H	K	L	LH	M	N	PA	PB
12	10	12	8	1	6	M5×0.8	16.3	23	5	11	17	3	4	—	4.3	$\phi 6.5 \times 4.5$ depth, M5×0.8×7.5depth	6.5	6
16	10	12	8	1.5	6	M5×0.8	19.8	28	5	11	17.5	3	4	—	4.3	$\phi 6.5 \times 4.5$ depth, M5×0.8×7.5depth	7	6.5
20	13	15	10	1.5	8	M5×0.8	24	—	6	15	20.5	3	5	—	4.3	$\phi 6.5 \times 4.5$ depth, M5×0.8×7.5depth	7.5	—
25	15	17	13	2	10	M5×0.8	28	—	8	17	23	3	5	—	5.1	$\phi 9 \times 7$ depth, M6×1.0×10depth	8	—
32	15	18	17	3	12	Rc1/8 (*1)	34	—	10	22	25	3	6	48.5	5.1	$\phi 9 \times 7$ depth, M6×1.0×10depth	9	—
40	25	28	22	3	16	Rc1/8 (*1)	40	—	14	28	35	3	8	56.5	6.9	$\phi 10.5 \times 8$ depth, M8×1.25×12depth	10	—
50	25	28	26	4	20	Rc1/4 (*2)	48	—	17	38	37	3	11	70	6.9	$\phi 11 \times 8.5$ depth, M8×1.25×16.5depth	10	—
63	25	28	26	4	20	Rc1/4 (*2)	60	—	17	40	37	3	11	83	6.9	$\phi 11 \times 8.5$ depth, M8×1.25×16.5depth	12	—
80	30	33	32	5	25	Rc3/8 (*3)	74	—	22	45	44	4	13	102	10.5	$\phi 14 \times 10.5$ depth, M12×1.75×12depth	13	—
100	35	38	35	5	30	Rc3/8 (*3)	90	—	27	55	50	4	14	122	12.3	$\phi 18.5 \times 13$ depth, M14×2×17depth	17	—

*1. Without magnet with stroke=5mm, EE=M5×0.8

*3. Without magnet with stroke=5mm, EE=Rc1/4

*2. Without magnet with stroke=5mm, EE=Rc1/8

Code Tube I.D.	Q	T	V	V1	X	Y	Z	Without magnet		Magnet	
								S	ZZ	S	ZZ
12	M5×0.8	—	25	32	3.2	6.3	1	17	34	27	44
16	M5×0.8	—	29	38	3.2	6.3	1	18.5	36	28.5	46
20	M6×1.0	—	34	—	3.2	6.3	1	19.5	40	29.5	50
25	M8×1.25	—	40	—	4.2	7.8	1	21	44	31	54
32	M10×1.25	14	44	—	4.2	7.8	1	24.5	49.5	34.5	59.5
40	M14×1.5	14	52	—	6.2	10.3	1.6	26	61	36	71
50	M18×1.5	19	62	—	6.2	10.8	1.6	28	65	38	75
63	M18×1.5	20	75	—	6.2	10.8	1.6	32	69	42	79
80	M22×1.5	27	94	—	8.2	13.8	1.6	41	85	51	95
100	M26×1.5	26	114	—	10.2	17.3	2	51	101	61	111

COMPACT CYLINDER

mindman

$\phi 12, \phi 16$

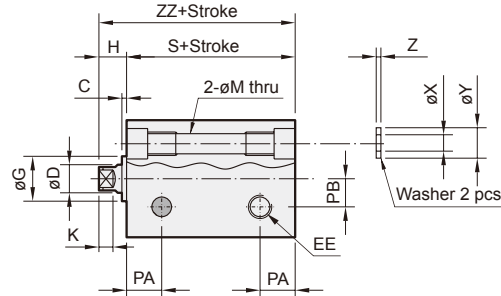
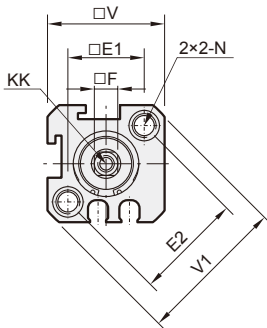

Long stroke

Without counter bore

With magnet type:
The stroke length must be over 100mm.
Without magnet type:
The stroke length must be over 110mm.

$\phi 12, \phi 16$



$\phi 20\sim\phi 50$



$\phi 20, \phi 25$

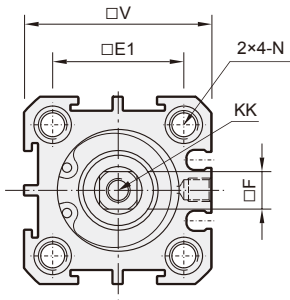

$\phi 32\sim\phi 50$

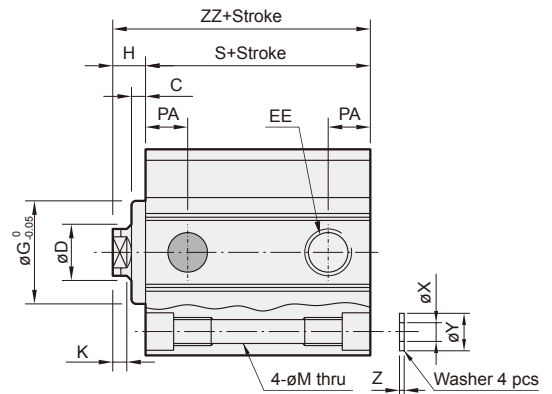
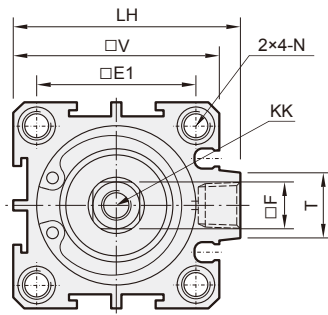

Code Tube I.D.	C	D	EE	E1	E2	F	G	H	K	KK	LH	M	N	PA	PB
12	1	6	M5×0.8	16.3	23	5	11	5	3	M3×0.5×6depth	—	4.3	ø6.5×4.5depth, M5×0.8×7.5depth	6.5	6
16	1.5	6	M5×0.8	19.8	28	5	11	5.5	3	M3×0.5×6depth	—	4.3	ø6.5×4.5depth, M5×0.8×7.5depth	7	6.5
20	1.5	8	M5×0.8	24	—	6	15	5.5	3	M4×0.7×8depth	—	4.3	ø6.5×4.5depth, M5×0.8×7.5depth	7.5	—
25	2	10	M5×0.8	28	—	8	17	6	3	M5×0.8×10depth	—	5.1	ø9×7depth, M6×1.0×10depth	8	—
32	3	12	Rc1/8	34	—	10	22	7	3	M6×1.0×12depth	48.5	5.1	ø9×7depth, M6×1.0×10depth	9	—
40	3	16	Rc1/8	40	—	14	28	7	3	M8×1.25×12depth	56.5	6.9	ø10.5×8depth, M8×1.25×12depth	10	—
50	4	20	Rc1/4 (*)	48	—	17	38	9	3	M10×1.5×15depth	70	6.9	ø11×8.5depth, M8×1.25×16.5depth	10	—

* Without magnet with stroke=5mm, EE=Rc1/8

Code Tube I.D.	T	V	V1	X	Y	Z
12	—	25	32	3.2	6.3	1
16	—	29	38	3.2	6.3	1
20	—	34	—	3.2	6.3	1
25	—	40	—	4.2	7.8	1
32	14	44	—	4.2	7.8	1
40	14	52	—	6.2	10.3	1.6
50	19	62	—	6.2	10.8	1.6

Code Tube I.D.	Without magnet				Magnet			
	Stroke 5,10		Stroke 15~30		Stroke 5,10		Stroke 15~30	
	S	ZZ	S	ZZ	S	ZZ	S	ZZ
12	27	32	37	42	37	42	47	52
16	28.5	34	38.5	44	38.5	44	48.5	54
20	29.5	35	39.5	45	39.5	45	49.5	55
25	31	37	41	47	41	47	51	57
32	34.5	41.5	44.5	51.5	44.5	51.5	54.5	61.5
40	36	43	46	53	46	53	56	63

Code Tube I.D.	Without magnet		Magnet	
	Stroke 5~20			
	S	ZZ	S	ZZ
50	28	37	38	47

Single acting – Table for standard stroke

Tube I.D.	Stroke (mm)
$\phi 12, 16, 20, 25, 32, 40$	5, 10, 15, 20, 25, 30
$\phi 50$	5, 10, 15, 20

• Please reconfirm dimension with our sales department when the stroke over our standard.

COMPACT CYLINDER

mindman

$\phi 12, \phi 16$

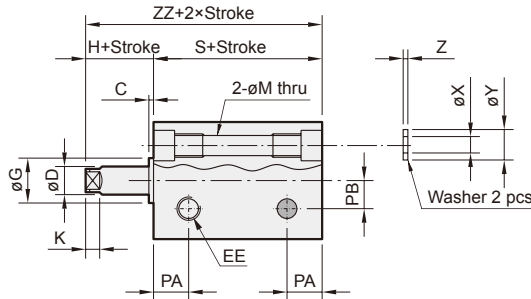
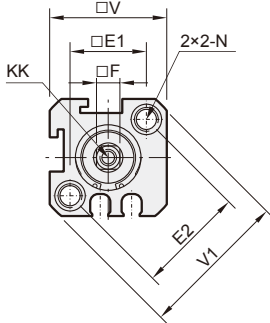

Long stroke

Without counter bore

With magnet type:
The stroke length must be over 100mm.
Without magnet type:
The stroke length must be over 110mm.

$\phi 12, \phi 16$



$\phi 20\sim\phi 50$

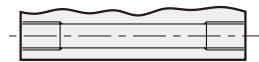

$\phi 20, \phi 25$

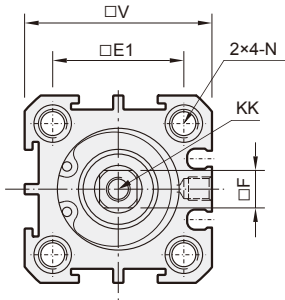

$\phi 32\sim\phi 50$

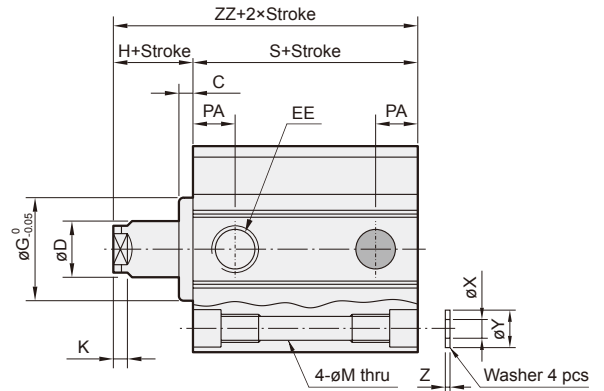
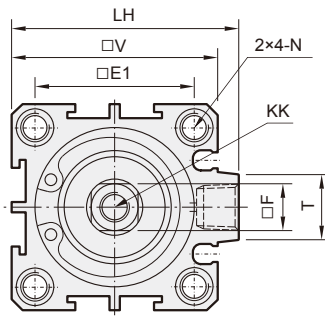

Code Tube I.D.	C	D	EE	E1	E2	F	G	H	K	KK	LH	M	N	PA	PB
12	1	6	M5×0.8	16.3	23	5	11	5	3	M3×0.5×6depth	—	4.3	φ6.5×4.5depth, M5×0.8×7.5depth	6.5	6
16	1.5	6	M5×0.8	19.8	28	5	11	5.5	3	M3×0.5×6depth	—	4.3	φ6.5×4.5depth, M5×0.8×7.5depth	7	6.5
20	1.5	8	M5×0.8	24	—	6	15	5.5	3	M4×0.7×8depth	—	4.3	φ6.5×4.5depth, M5×0.8×7.5depth	7.5	—
25	2	10	M5×0.8	28	—	8	17	6	3	M5×0.8×10depth	—	5.1	φ9×7depth, M6×1.0×10depth	8	—
32	3	12	Rc1/8	34	—	10	22	7	3	M6×1.0×12depth	48.5	5.1	φ9×7depth, M6×1.0×10depth	9	—
40	3	16	Rc1/8	40	—	14	28	7	3	M8×1.25×12depth	56.5	6.9	φ10.5×8depth, M8×1.25×12depth	10	—
50	4	20	Rc1/4 (*)	48	—	17	38	9	3	M10×1.5×15depth	70	6.9	φ11×8.5depth, M8×1.25×16.5depth	10	—

* Without magnet with stroke=5mm, EE=Rc1/8

Code Tube I.D.	T	V	V1	X	Y	Z
12	—	25	32	3.2	6.3	1
16	—	29	38	3.2	6.3	1
20	—	34	—	3.2	6.3	1
25	—	40	—	4.2	7.8	1
32	14	44	—	4.2	7.8	1
40	14	52	—	6.2	10.3	1.6
50	19	62	—	6.2	10.8	1.6

Code Tube I.D.	Without magnet				Magnet			
	Stroke 5,10		Stroke 15~30		Stroke 5,10		Stroke 15~30	
	S	ZZ	S	ZZ	S	ZZ	S	ZZ
12	27	32	37	42	37	42	47	52
16	28.5	34	38.5	44	38.5	44	48.5	54
20	29.5	35	39.5	45	39.5	45	49.5	55
25	31	37	41	47	41	47	51	57
32	34.5	41.5	44.5	51.5	44.5	51.5	54.5	61.5
40	36	43	46	53	46	53	56	63

Code Tube I.D.	Without magnet		Magnet	
	Stroke 5~20			
	S	ZZ	S	ZZ
50	28	37	38	47

Single acting – Table for standard stroke

Tube I.D.	Stroke (mm)
$\phi 12, 16, 20, 25, 32, 40$	5, 10, 15, 20, 25, 30
$\phi 50$	5, 10, 15, 20

* Please reconfirm dimension with our sales department when the stroke over our standard.

Double acting

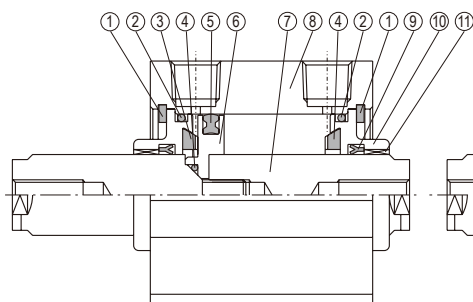

Single acting

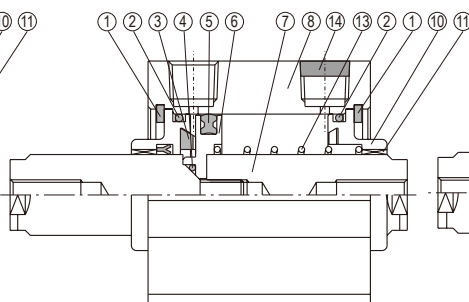

Double acting

(with magnet)

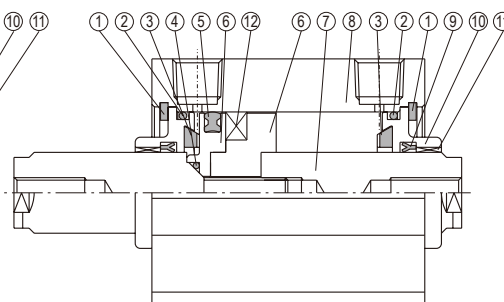

Double acting

Adjustable stroke

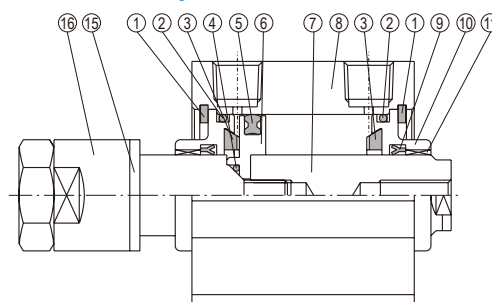

Seal kit

Acting type	Rod packing		Piston packing		Cover ring	Piston gasket
	Double acting	Single acting	Double acting	Single acting	Double acting single acting	Double acting single acting
Q'y	2	1	1	1	2	1
12	KSYR-6	KSYR-6	OPA-12	OPA-12	d11×w1	d4×w1
16	KSYR-6	KSYR-6	OPA-16	OPA-16	S-14	d4×w1
20	KSYR-8	KSYR-8	OPA-20	OPA-20	S-18	d6×w1
25	KSYR-10	KSYR-10	OPA-25	OPA-25	S-22	d6×w1
32	KSYR-12	KSYR-12	OPA-32	OPA-32	d28×w2	d8×w1
40	KSYR-16	KSYR-16	OPA-40	OPA-40	S-36	d11×w1
50	KSYR-20	KSYR-20	OPA-50	OPA-50	AS-31	S-14
63	KSYR-20	—	OPA-63	—	AS-35	S-14
80	ORA-25	—	OPA-80	—	AS-41	S-18
100	SDR-30	—	OPA-100	—	S-95	S-26

Material

No.	Tube I.D. Part name	12	16	20	25	32	40	50	63	80	100	Q'y	Component parts (inclusion)	Repair kits (inclusion)
1	Snap ring (Front end)	SUS	Spring steel	SUS	Spring steel						2	●		
2	Cover ring				NBR						2	●	●	
3	Cushion packing	—	NBR									2	●	●
4	Piston gasket				NBR						1	●	●	
5	Piston packing				NBR						1	●	●	
6	Piston				Aluminum alloy						1	●		
7	Piston rod	SUS			Carbon steel						2			
	With magnet	SUS			Carbon steel						2			
8	Body				Aluminum alloy						1			
9	Rod packing				NBR						2 ^(*)	●	●	
10	Rod cover				Aluminum alloy						2	●		
11	Bush	—			Bearing alloy						2	●		
12	Magnet ring				Magnet material						1	●		
13	Spring				SWP						1	●		
14	Silencer				Brass						1	●		
15	Cushion packing				PU						1	●		
16	Adjustable nut				Carbon steel						1	●		

* Single acting type, Q'y=1

Order example Component parts

Tube I.D.	Component parts
ø12	CP-MCJA-2-12(M)
ø16	CP-MCJA-2-16(M)
ø20	CP-MCJA-2-20(M)
ø25	CP-MCJA-2-25(M)
ø32	CP-MCJA-2-32(M)
ø40	CP-MCJA-2-40(M)
ø50	CP-MCJA-2-50(M)
ø63	CP-MCJA-2-63(M)
ø80	CP-MCJA-2-80(M)
ø100	CP-MCJA-2-100(M)

M: With magnet

Repair kits

Tube I.D.	Repair kits
ø12	PS-MCJA-2-12
ø16	PS-MCJA-2-16
ø20	PS-MCJA-2-20
ø25	PS-MCJA-2-25
ø32	PS-MCJA-2-32
ø40	PS-MCJA-2-40
ø50	PS-MCJA-2-50
ø63	PS-MCJA-2-63
ø80	PS-MCJA-2-80
ø100	PS-MCJA-2-100

COMPACT CYLINDER

mindman

$\varnothing 12, \varnothing 16$

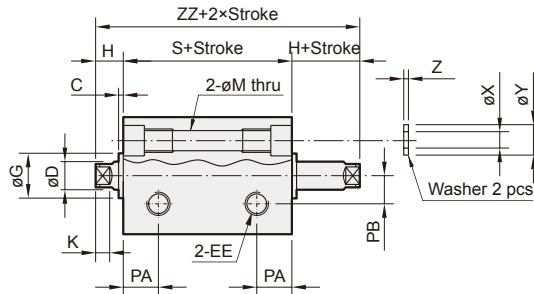
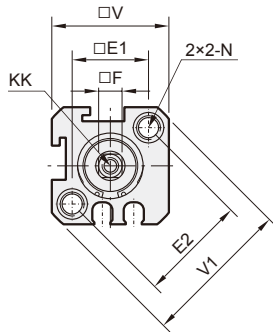

Long stroke

Without counter bore

With magnet type:

The stroke length must be over 100mm.

Without magnet type:

The stroke length must be over 110mm.

$\varnothing 12, \varnothing 16$



$\varnothing 20\sim\varnothing 100$

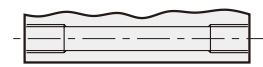

$\varnothing 20, \varnothing 25$

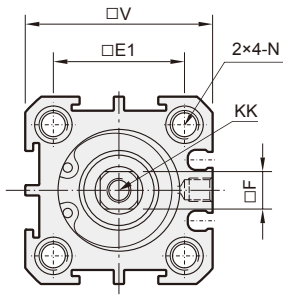

$\varnothing 32\sim\varnothing 100$

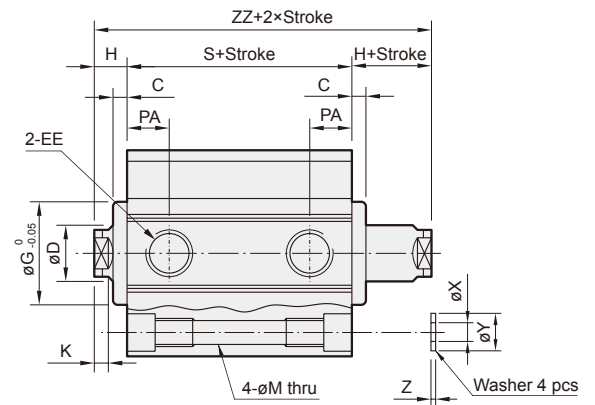
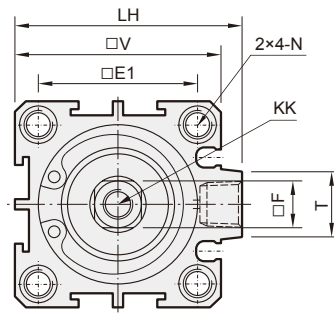

Code Tube I.D.	C	D	EE	E1	E2	F	G	H	K	KK	LH	M	N	PA	PB
12	1	6	M5×0.8	16.3	23	5	11	5	3	M3×0.5×6depth	—	4.3	$\varnothing 6.5 \times 4.5$ depth, M5×0.8×7.5depth	6.5	6
16	1.5	6	M5×0.8	19.8	28	5	11	5.5	3	M3×0.5×6depth	—	4.3	$\varnothing 6.5 \times 4.5$ depth, M5×0.8×7.5depth	7	6.5
20	1.5	8	M5×0.8	24	—	6	15	5.5	3	M4×0.7×8depth	—	4.3	$\varnothing 6.5 \times 4.5$ depth, M5×0.8×7.5depth	7.5	—
25	2	10	M5×0.8	28	—	8	17	6	3	M5×0.8×10depth	—	5.1	$\varnothing 9 \times 7$ depth, M6×1.0×10depth	8	—
32	3	12	Rc1/8 (*1)	34	—	10	22	7	3	M6×1.0×12depth	48.5	5.1	$\varnothing 9 \times 7$ depth, M6×1.0×10depth	9	—
40	3	16	Rc1/8 (*1)	40	—	14	28	7	3	M8×1.25×12depth	56.5	6.9	$\varnothing 10.5 \times 8$ depth, M8×1.25×12depth	10	—
50	4	20	Rc1/4 (*2)	48	—	17	38	9	3	M10×1.5×15depth	70	6.9	$\varnothing 11 \times 8.5$ depth, M8×1.25×16.5depth	10	—
63	4	20	Rc1/4 (*2)	60	—	17	40	9	3	M10×1.5×15depth	83	6.9	$\varnothing 11 \times 8.5$ depth, M8×1.25×16.5depth	12	—
80	5	25	Rc3/8 (*3)	74	—	22	45	11	4	M14×1.5×20depth	102	10.5	$\varnothing 14 \times 10.5$ depth, M12×1.75×12depth	13	—
100	5	30	Rc3/8 (*3)	90	—	27	55	12	4	M18×1.5×20depth	122	12.3	$\varnothing 18.5 \times 13$ depth, M14×2×17depth	17	—

*1. Without magnet with stroke=5mm, EE=M5×0.8

*3. Without magnet with stroke=5mm, EE=Rc1/4

*2. Without magnet with stroke=5mm, EE=Rc1/8

Code Tube I.D.	T	V	V1	X	Y	Z	Without magnet		Magnet	
							S	ZZ	S	ZZ
12	—	25	32	3.2	6.3	1	17	27	27	37
16	—	29	38	3.2	6.3	1	18.5	29.5	28.5	39.5
20	—	34	—	3.2	6.3	1	19.5	30.5	29.5	40.5
25	—	40	—	4.2	7.8	1	21	33	31	43
32	14	44	—	4.2	7.8	1	24.5	38.5	34.5	48.5
40	14	52	—	6.2	10.3	1.6	26	40	36	50
50	19	62	—	6.2	10.8	1.6	28	46	38	56
63	20	75	—	6.2	10.8	1.6	32	50	42	60
80	27	94	—	8.2	13.8	1.6	41	63	51	73
100	26	114	—	10.2	17.3	2	51	75	61	85

COMPACT CYLINDER

$\phi 12, \phi 16$

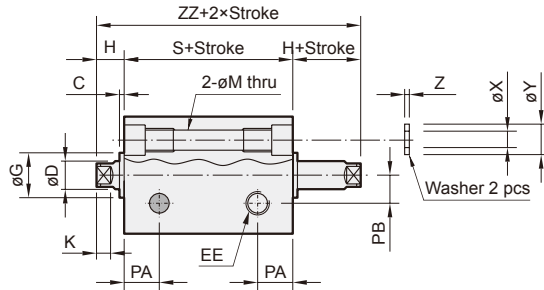
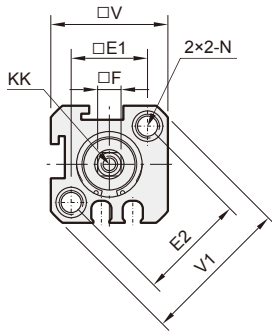

Long stroke

Without counter bore

With magnet type:
The stroke length must be over 100mm.
Without magnet type:
The stroke length must be over 110mm.

$\phi 12, \phi 16$



$\phi 20\sim\phi 50$

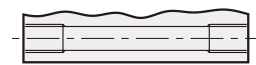

$\phi 20, \phi 25$

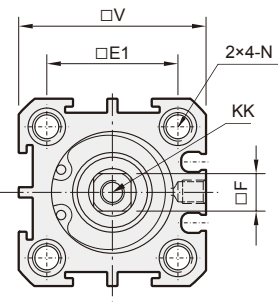

$\phi 32\sim\phi 50$

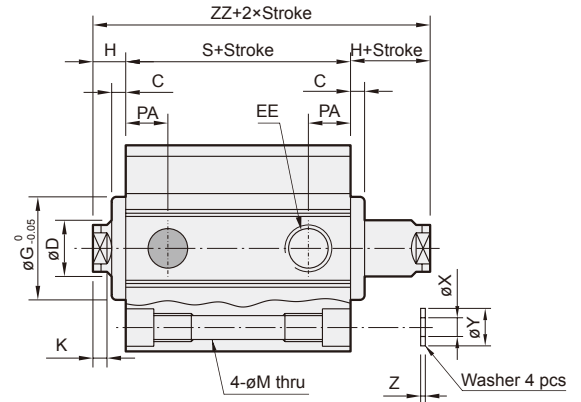
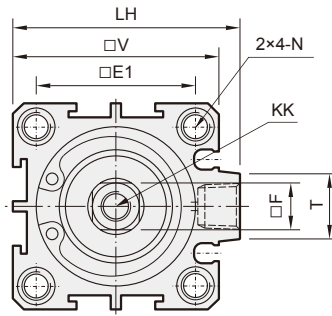

Code Tube I.D.	C	D	EE	E1	E2	F	G	H	K	KK	LH	M	N	PA	PB
12	1	6	M5×0.8	16.3	23	5	11	5	3	M3×0.5×6depth	—	4.3	$\phi 6.5\times 4.5$ depth, M5×0.8×7.5depth	6.5	6
16	1.5	6	M5×0.8	19.8	28	5	11	5.5	3	M3×0.5×6depth	—	4.3	$\phi 6.5\times 4.5$ depth, M5×0.8×7.5depth	7	6.5
20	1.5	8	M5×0.8	24	—	6	15	5.5	3	M4×0.7×8depth	—	4.3	$\phi 6.5\times 4.5$ depth, M5×0.8×7.5depth	7.5	—
25	2	10	M5×0.8	28	—	8	17	6	3	M5×0.8×10depth	—	5.1	$\phi 9\times 7$ depth, M6×1.0×10depth	8	—
32	3	12	Rc1/8	34	—	10	22	7	3	M6×1.0×12depth	48.5	5.1	$\phi 9\times 7$ depth, M6×1.0×10depth	9	—
40	3	16	Rc1/8	40	—	14	28	7	3	M8×1.25×12depth	56.5	6.9	$\phi 10.5\times 8$ depth, M8×1.25×12depth	10	—
50	4	20	Rc1/4 (*)	48	—	17	38	9	3	M10×1.5×15depth	70	6.9	$\phi 11\times 8.5$ depth, M8×1.25×16.5depth	10	—

* Without magnet with stroke=5mm, EE=Rc1/8

Code Tube I.D.	T	V	V1	X	Y	Z
12	—	25	32	3.2	6.3	1
16	—	29	38	3.2	6.3	1
20	—	34	—	3.2	6.3	1
25	—	40	—	4.2	7.8	1
32	14	44	—	4.2	7.8	1
40	14	52	—	6.2	10.3	1.6
50	19	62	—	6.2	10.8	1.6

Code Tube I.D.	Without magnet				Magnet			
	Stroke 5,10		Stroke 15~30		Stroke 5,10		Stroke 15~30	
	S	ZZ	S	ZZ	S	ZZ	S	ZZ
12	27	37	37	47	37	47	47	57
16	28.5	39.5	38.5	49.5	38.5	49.5	48.5	59.5
20	29.5	40.5	39.5	50.5	39.5	50.5	49.5	60.5
25	31	43	41	53	41	53	51	63
32	34.5	48.5	44.5	58.5	44.5	58.5	54.5	68.5
40	36	50	46	60	46	60	56	70

Code Tube I.D.	Without magnet		Magnet	
	Stroke 5~20			
	S	ZZ	S	ZZ
50	28	46	38	56

Single acting – Table for standard stroke

Tube I.D.	Stroke (mm)
$\phi 12, 16, 20, 25, 32, 40$	5, 10, 15, 20, 25, 30
$\phi 50$	5, 10, 15, 20

* Please reconfirm dimension with our sales department when the stroke over our standard.

COMPACT CYLINDER

mindman

$\phi 12, \phi 16$

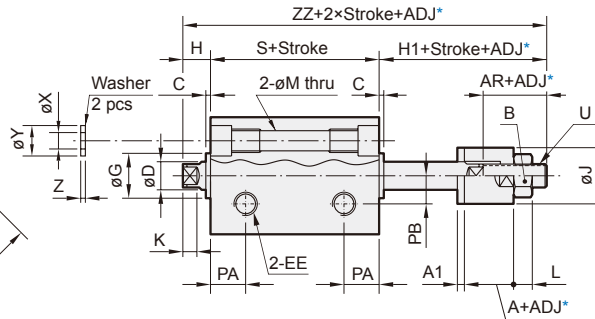
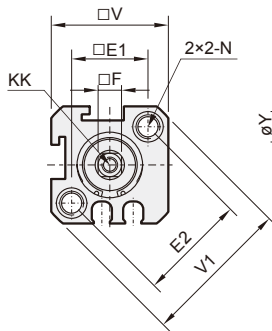

Long stroke

Without counter bore

With magnet type:
The stroke length must be over 100mm.
Without magnet type:
The stroke length must be over 110mm.

$\phi 12, \phi 16$



$\phi 20, \phi 100$



*ADJ: Adjustable stroke

$\phi 20, \phi 25$

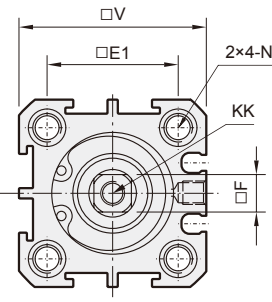

$\phi 32\sim\phi 100$

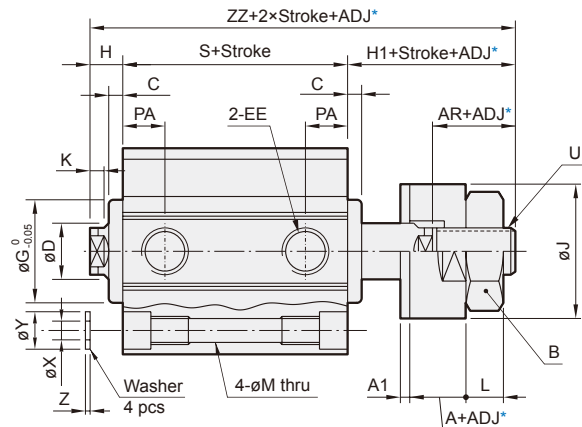
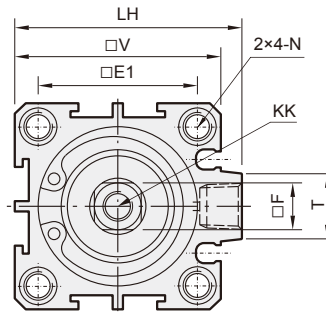

Code Tube I.D.	A	A1	AR	B	C	D	EE	E1	E2	F	G	H	H1	J	K	KK	L	LH	M
12	13	2	16	8	1	6	M5×0.8	16.3	23	5	11	5	22.5	12	3	M3×0.5×6depth	4	—	4.3
16	13	2	16.5	8	1.5	6	M5×0.8	19.8	28	5	11	5.5	23.5	12	3	M3×0.5×6depth	4	—	4.3
20	15	2	19	13	1.5	8	M5×0.8	24	—	6	15	5.5	26	16	3	M4×0.7×8depth	5	—	4.3
25	15	2	19.5	13	2	10	M5×0.8	28	—	8	17	6	27.2	16	3	M5×0.8×10depth	5	—	5.1
32	12	2	18	17	3	12	Rc1/8 (*1)	34	—	10	22	7	26	20	3	M6×1.0×12depth	6	48.5	5.1
40	12	2	20	19	3	16	Rc1/8 (*1)	40	—	14	28	7	28	30	3	M8×1.25×12depth	7	56.5	6.9
50	15	2	22	24	4	20	Rc1/4 (*2)	48	—	17	38	9	31	40	3	M10×1.5×15depth	8	70	6.9
63	15	2	22	24	4	20	Rc1/4 (*2)	60	—	17	40	9	31	40	3	M10×1.5×15depth	8	83	6.9
80	20	3	33	32	5	25	Rc3/8 (*3)	74	—	22	45	11	44	50	4	M14×1.5×20depth	13	102	10.5
100	20	3	33	32	5	30	Rc3/8 (*3)	90	—	27	55	12	44	50	4	M18×1.5×20depth	13	122	12.3

*1. Without magnet with stroke=5mm, EE=M5×0.8

*3. Without magnet with stroke=5mm, EE=Rc1/4

*2. Without magnet with stroke=5mm, EE=Rc1/8

Code Tube I.D.	N	PA	PB	T	U	V	V1	X	Y	Z	Without magnet		Magnet	
											S	ZZ	S	ZZ
12	$\phi 6.5 \times 4.5$ depth, M5×0.8×7.5depth	6.5	6	—	M5×0.8	25	32	3.2	6.3	1	17	44.5	27	54.5
16	$\phi 6.5 \times 4.5$ depth, M5×0.8×7.5depth	7	6.5	—	M5×0.8	29	38	3.2	6.3	1	18.5	47.5	28.5	57.5
20	$\phi 6.5 \times 4.5$ depth, M5×0.8×7.5depth	7.5	—	—	M8×1.25	34	—	3.2	6.3	1	19.5	51	29.5	61
25	$\phi 9 \times 7$ depth, M6×1.0×10depth	8	—	—	M8×1.25	40	—	4.2	7.8	1	21	54.2	31	64.2
32	$\phi 9 \times 7$ depth, M6×1.0×10depth	9	—	14	M10×1.25	44	—	4.2	7.8	1	24.5	57.5	34.5	67.5
40	$\phi 10.5 \times 8$ depth, M8×1.25×12depth	10	—	14	M12×1.25	52	—	6.2	10.3	1.6	26	61	36	71
50	$\phi 11 \times 8.5$ depth, M8×1.25×16.5depth	10	—	19	M16×1.5	62	—	6.2	10.8	1.6	28	68	38	78
63	$\phi 11 \times 8.5$ depth, M8×1.25×16.5depth	12	—	20	M16×1.5	75	—	6.2	10.8	1.6	32	72	42	82
80	$\phi 14 \times 10.5$ depth, M12×1.75×12depth	13	—	27	M22×1.5	94	—	8.2	13.8	1.6	41	96	51	106
100	$\phi 18.5 \times 13$ depth, M14×2×17depth	17	—	26	M22×1.5	114	—	10.2	17.3	2	51	107	61	117

COMPACT CYLINDER

mindman

$\phi 12, \phi 16$

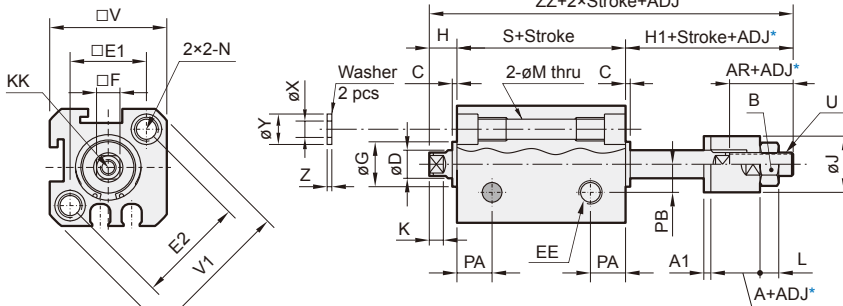

*ADJ: Adjustable stroke

Long stroke

Without counter bore

With magnet type:
The stroke length must be over 100mm.
Without magnet type:
The stroke length must be over 110mm.

$\phi 12, \phi 16$



$\phi 20\sim\phi 50$

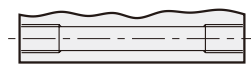

$\phi 20, \phi 25$

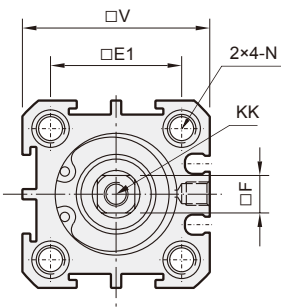

$\phi 32\sim\phi 50$

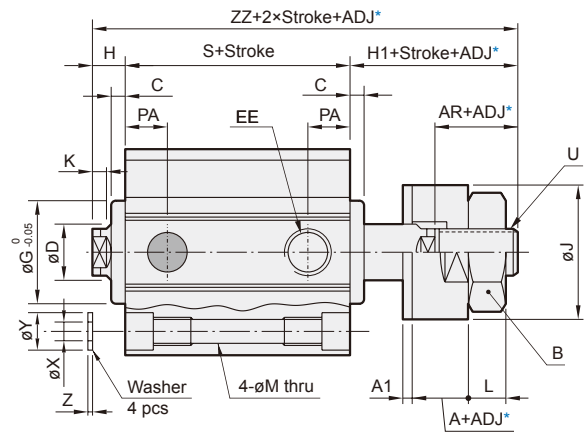
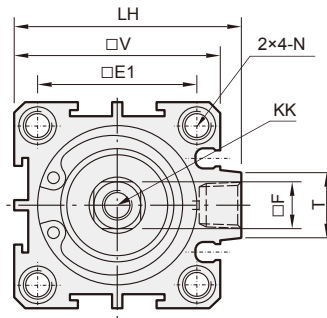

Code Tube I.D.	A	A1	AR	B	C	D	EE	E1	E2	F	G	H	H1	J	K	KK	L	LH	M	N
12	13	2	16	8	1	6	M5×0.8	16.3	23	5	11	5	22.5	12	3	M3×0.5×6depth	4	—	4.3	$\phi 6.5 \times 4.5$ depth, M5×0.8×7.5depth
16	13	2	16.5	8	1.5	6	M5×0.8	19.8	28	5	11	5.5	23.5	12	3	M3×0.5×6depth	4	—	4.3	$\phi 6.5 \times 4.5$ depth, M5×0.8×7.5depth
20	15	2	19	13	1.5	8	M5×0.8	24	—	6	15	5.5	26	16	3	M4×0.7×8depth	5	—	4.3	$\phi 6.5 \times 4.5$ depth, M5×0.8×7.5depth
25	15	2	19.5	13	2	10	M5×0.8	28	—	8	17	6	27.2	16	3	M5×0.8×10depth	5	—	5.1	$\phi 9 \times 7$ depth, M6×1.0×10depth
32	12	2	18	17	3	12	Rc1/8	34	—	10	22	7	26	20	3	M6×1.0×12depth	6	48.5	5.1	$\phi 9 \times 7$ depth, M6×1.0×10depth
40	12	2	20	19	3	16	Rc1/8	40	—	14	28	7	28	30	3	M8×1.25×12depth	7	56.5	6.9	$\phi 10.5 \times 8$ depth, M8×1.25×12depth
50	15	2	22	24	4	20	Rc1/4 (*)	48	—	17	38	9	31	40	3	M10×1.5×15depth	8	70	6.9	$\phi 11 \times 8.5$ depth, M8×1.25×16.5depth

* Without magnet with stroke=5mm, EE=Rc1/8

Code Tube I.D.	PA	PB	T	U	V	V1	X	Y	Z
12	6.5	6	—	M5×0.8	25	32	3.2	6.3	1
16	7	6.5	—	M5×0.8	29	38	3.2	6.3	1
20	7.5	—	—	M8×1.25	34	—	3.2	6.3	1
25	8	—	—	M8×1.25	40	—	4.2	7.8	1
32	9	—	14	M10×1.25	44	—	4.2	7.8	1
40	10	—	14	M12×1.25	52	—	6.2	10.3	1.6
50	10	—	19	M16×1.5	62	—	6.2	10.8	1.6

Code Tube I.D.	Without magnet				Magnet			
	Stroke 5,10		Stroke 15~30		Stroke 5,10		Stroke 15~30	
	S	ZZ	S	ZZ	S	ZZ	S	ZZ
12	27	54.5	37	64.5	37	64.5	47	74.5
16	28.5	57.5	38.5	67.5	38.5	67.5	48.5	77.5
20	29.5	61	39.5	71	39.5	71	49.5	81
25	31	64.2	41	74.2	41	74.2	51	84.2
32	34.5	67.5	44.5	77.5	44.5	77.5	54.5	87.5
40	36	71	46	81	46	81	56	91

Code Tube I.D.	Without magnet		Magnet	
	Stroke 5~20			
	S	ZZ	S	ZZ
50	28	68	38	78

Single acting – Table for standard stroke

Tube I.D.	Stroke (mm)
$\phi 12, 16, 20, 25, 32, 40$	5, 10, 15, 20, 25, 30
$\phi 50$	5, 10, 15, 20

* Please reconfirm dimension with our sales department when the stroke over our standard.

COMPACT CYLINDER

Mindman

Dimensions

**RCB
RNB**

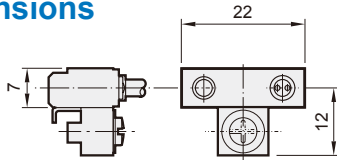

RCB, RNB: Red LED

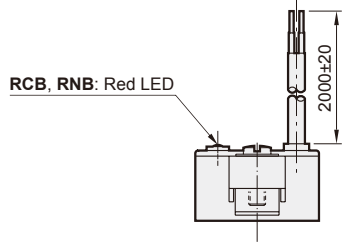

RCE

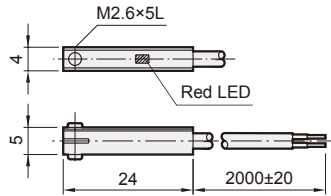

**RCE1
RNE**

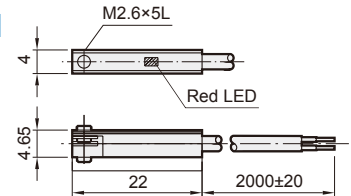

RDEP

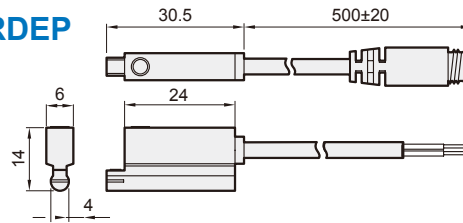

Installation of sensor switch

$\varnothing 12\sim\varnothing 40$

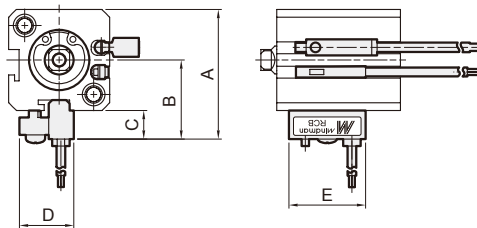

$\varnothing 50\sim\varnothing 100$

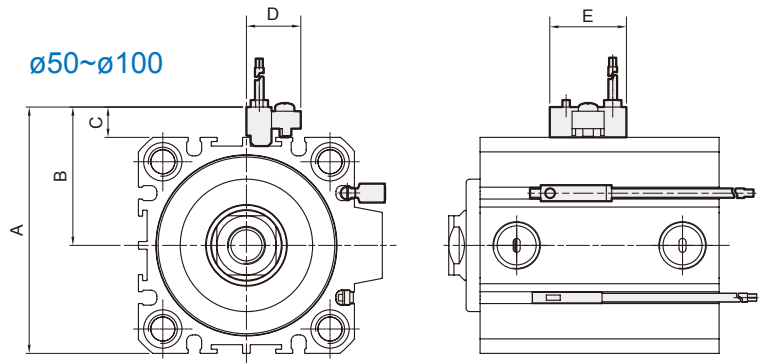

Order example

RCE1 — □

MODEL

RCB / RCE / RCE1 (C: Reed switch)
RNB / RNE (N: Solid state switch)
RDEP (Solid state switch)

WIRE LENGTH

Blank: L=2000m
1M: L=1000m
QD: M8 3Pin connector
EQD: M8 3Pin connector

Code Tube I.D.	A	B	C	D	E
12	33.5	21.5	8.5	16	22
16	37.5	23	8.5	16	22
20	42.5	25.5	8.5	16	22
25	49	29	9	16	22
32	53	31	9	16	22

Code Tube I.D.	A	B	C	D	E
40	61	35	9	16	22
50	71	40	9	16	22
63	84	46.5	9	16	22
80	103	56	9	16	22
100	123	66	9	16	22

Description

▼ RCB switch ▼ RCE, RCE1, RDEP switch ↓ Port

