

Dimension Drawings

NCL TYPE

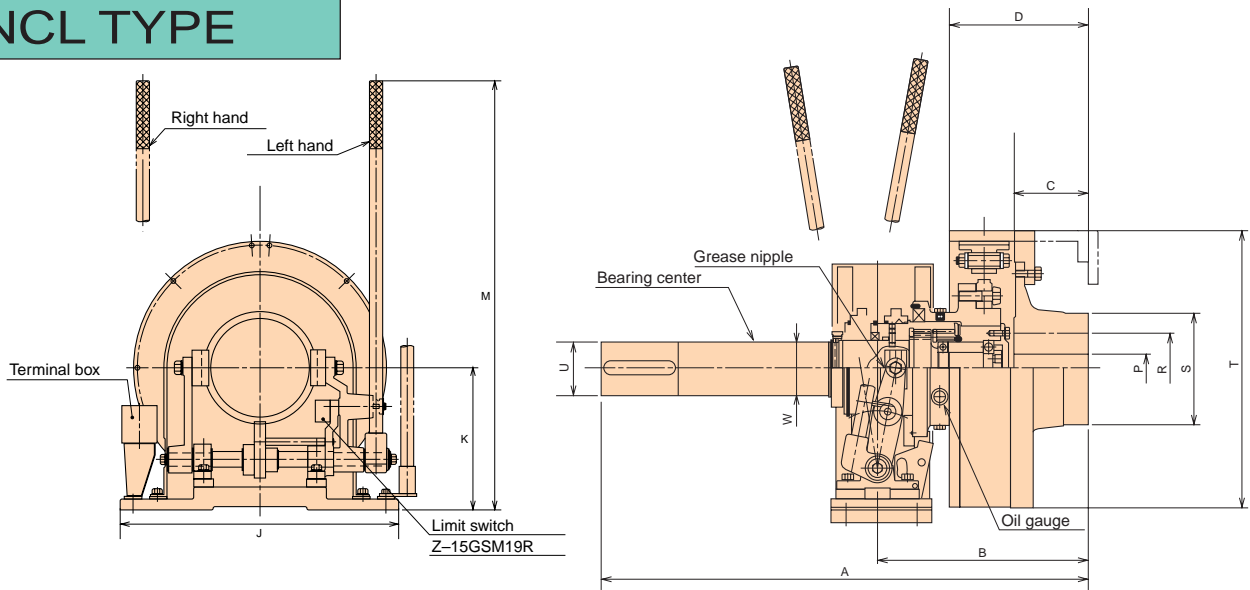

MARK		unit:mm												
MODEL TYPE	A	B	C	D	J	K	M	ϕP	ϕR	ϕS	ϕT	ϕU	ϕW	WEIGHT kg
NCL-136	853	335.5	90	200	600	280	673	30	85	143	367	70	85	145
NCL-156	1,008	421.5	127	243	600	280	673	45	115	178	414	85	95	195
NCL-186	1,215	537.5	152	286	630	320	913	65	150	230	494	95	110	290
NCL-218	1,148	470.5	152	284	630	320	913	65	150	230	576	95	110	350
NCL-248	1,330	522.0	153	331	680	320	965	70	165	254	656	125	150	520
NCL-308	1,432	614.0	203	381	740	370	1,126	75	200	305	817	140	190	890

NCL-1B TYPE

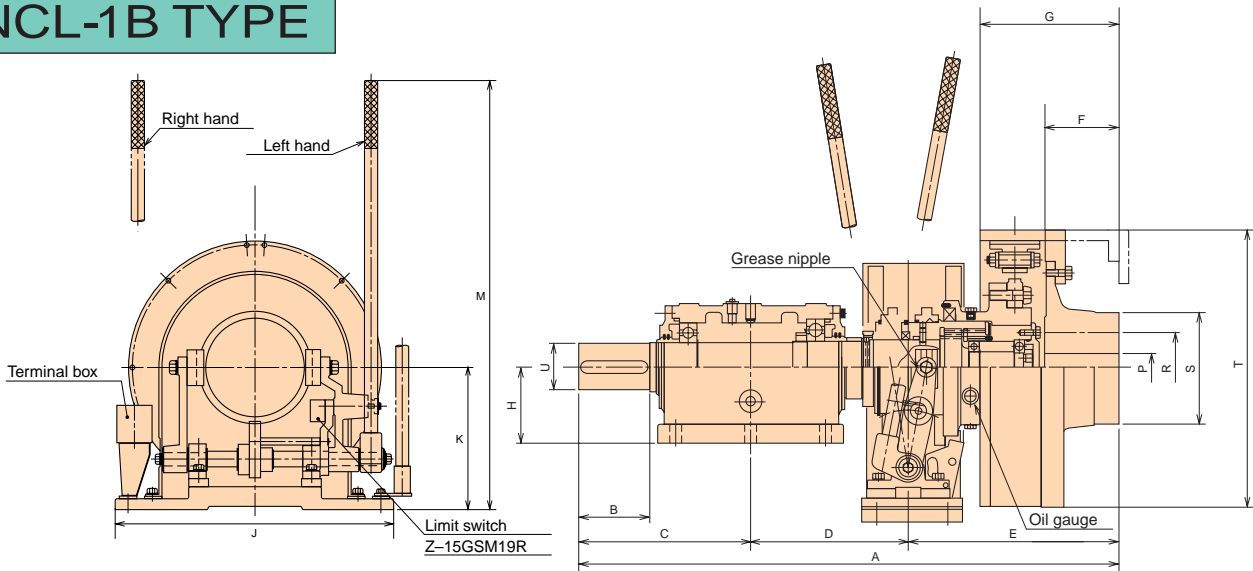

MARK		unit:mm																
MODEL TYPE	A	B	C	D	E	F	G	H	J	K	M	ϕP	ϕR	ϕS	ϕT	ϕU	WEIGHT kg	
NCL1B-136	853	90	260	269.5	335.5	90	200	125	600	280	673	30	85	143	367	70	205	
NCL1B-156	1,008	110	300	286.5	421.5	127	243	140	600	280	673	45	115	178	414	85	255	
NCL1B-186	1,215	145	355	322.5	537.5	152	286	155	630	320	913	65	150	230	494	95	350	
NCL1B-218	1,148	145	355	322.5	470.5	152	284	155	630	320	913	65	150	230	576	95	425	
NCL1B-248	1,330	160	418	390.0	522.0	153	331	190	680	320	965	70	165	254	656	125	600	
NCL1B-308	1,432	170	430	388.0	614.0	203	381	215	740	370	1,126	75	200	305	817	140	970	